

# *Transformer Oil Regeneration*

*E575R Series*



*for*

*Power Companies*

*and the*

*Electrical Industry*

***ENERVAC***  
CORPORATION



## Description of Process

Used oil is strained, heated and filtered prior to flowing into a bank of columns which are filled with an adsorbent media. The oil's primary physical parameters are restored during this phase. Upon exiting the columns, the oil is passed through a degassification unit and an afterfilter which restores the oil to virgin conditions. The banks of columns eventually become saturated and need to be reactivated. This reactivation is performed within the columns and does not require the adsorbent to be removed. The reactivation process typically takes 12 hours, during which time a second bank is used to process oil. ENERVAC's unique control system allows for 24 hour processing without having to shut the E575R down. Once reactivated the bank is again ready for processing. On average, between 300 and 500 reactivations per bank ensure that the media only needs to be changed every three to five years. Once exhausted, the media is reactivated one final time and is then discarded as a dry waste in a normal landfill - it is completely devoid of any oily waste.

The increasing rating requirements of modern transformers and electrical apparatus results in greater electrical stress in insulating material and fluids. In order to handle these greater stresses, oils are required to have better dielectric strength, and lower residual water content must be maintained. The timely and proper treatment of these insulating fluids will result in the improvement of the properties of the entire insulating system of power transformers.

The principal functions of the insulating fluid are to serve as a dielectric material and an effective coolant. To perform these functions, the insulating fluid must have specific necessary qualities at the time of initial impregnation and filling at the factory which must be maintained at the same quality level in field operation if optimum performance is to be assured.

Transformer oils deteriorate with time. High operating temperatures, the presence of oxygen and water combined with the catalytic action of the materials within the transformer, result in oxidation and cracking of the oil. The byproducts of oxidation are acidic and the long-term effect of these byproducts results in an exponential increase in deterioration of the transformer and its oil. The resulting sludge build-up reduces the cooling effects of the oil driving the whole decay mechanism at an increasingly accelerated rate. The acid number becomes exponential around the 0.25 mg KOH/g oil level. Preventative measures must be undertaken prior to the oil acidity level climbing to this point. Generally, the larger the transformer plate rating, the lower the acid number that triggers regeneration of the oil.

Historically, Fullers Earth has been used to reduce the acid number on a one-time batch basis then disposed of. There are obvious disadvantages to this, not least the environmental impact of dumping oily waste into a landfill.

The ENERVAC E575R Transformer Oil Regeneration System provides an extremely cost-effective and environmentally acceptable method of extending transformer oil lifetime to over 100 years!

The mobile ENERVAC E575R is ideally suited for processing transformers that are either on- or off-load and the skid-mounted E575R is well suited for tank farm applications.



# *Restore used transformer oils to*

## Typical Performance of Enervac E575R system

Parameter	Test	Unit	Used oil	After regeneration
Appearance			Cloudy, brown	Sparkling, yellow
Colour	ASTM D-1500	L	3.5	0.5
Corrosive sulphur	ASTM D-1275		Corrosive	Non-corrosive
Dielectric breakdown	ASTM D-1816	kV	11	73
Gas content	ASTM D-3612	%	12	0.1
IFT	ASTM D-2285	Dynes/cm	22	45
Neutralisation number	ASTM D-664	mg KOH/g oil	0.63	0.01
Oxidation test – Neutralisation number	IP-307	mg KOH/g oil	-	0.2
Particle size		micron	50	1
Resistivity @ 20°C	ASTM D-1169	G Ohm m	10	17000
Resistivity @ 90°C	ASTM D-1169	G Ohm m	0.5	500
Sludge	ASTM D-1698	%	1	0.03
Tan delta @ 90°C	ASTM D-924		4.0	0.001
Water content	ASTM D-1533	mg/kg	1700	5

## Model Nomenclature Chart

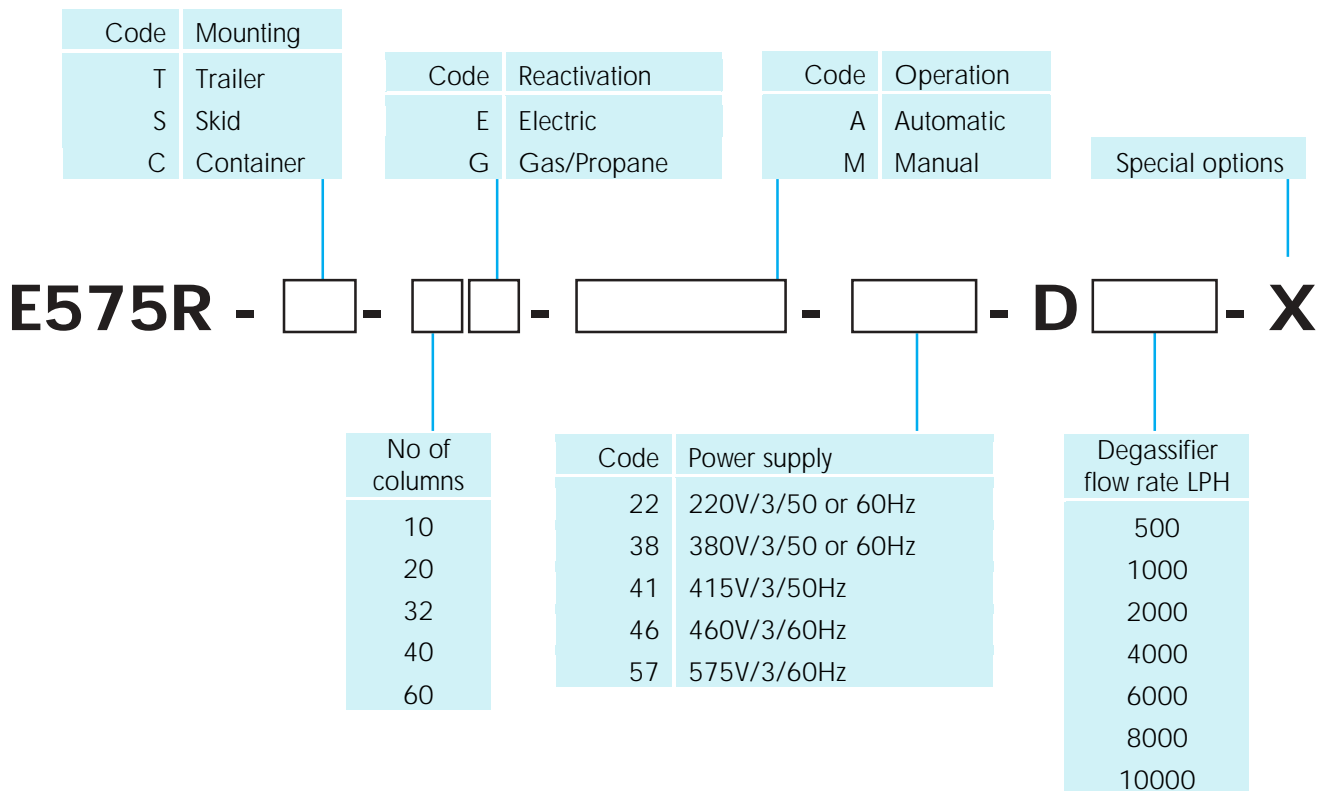

*better than new oil specifications!*



## Features

- Open technology - no "black box" or restricted plant areas
- Royalty-free operation - no gallonage or reactivation fees
- Full 24 hour operation - dual banks allow reactivation with simultaneous processing
- On-load and off-load transformer processing with ENERVAC's Transformer Oil Level Monitoring System (TOLMS)
- Multi-mode maximises flexibility - can be used as conventional degassifier with transformer dry-out capabilities
- DBPC anti-oxidant blend back facility
- Customised control options from fully automatic with PC control and datalogging, manual override options, PLC control, mimic panel
- Full laboratory option
- Boiler option
- Onboard generator option
- All global power supply options offered



Representative:

**ENERVAC**  
CORPORATION

700 Franklin Boulevard, Cambridge, Ontario, Canada N1R 5S9  
Telephone +1 (519) 623-9890 Facsimile +1 (519) 623-8250  
E-mail: [sales@enervac.com](mailto:sales@enervac.com) Website: [www.enervac.com](http://www.enervac.com)